

145450

DRAFT

PRELIMINARY

OPERATION MANUAL

DECEMBER 1994

*Grand 443-8478
3 766 9824
The Don*

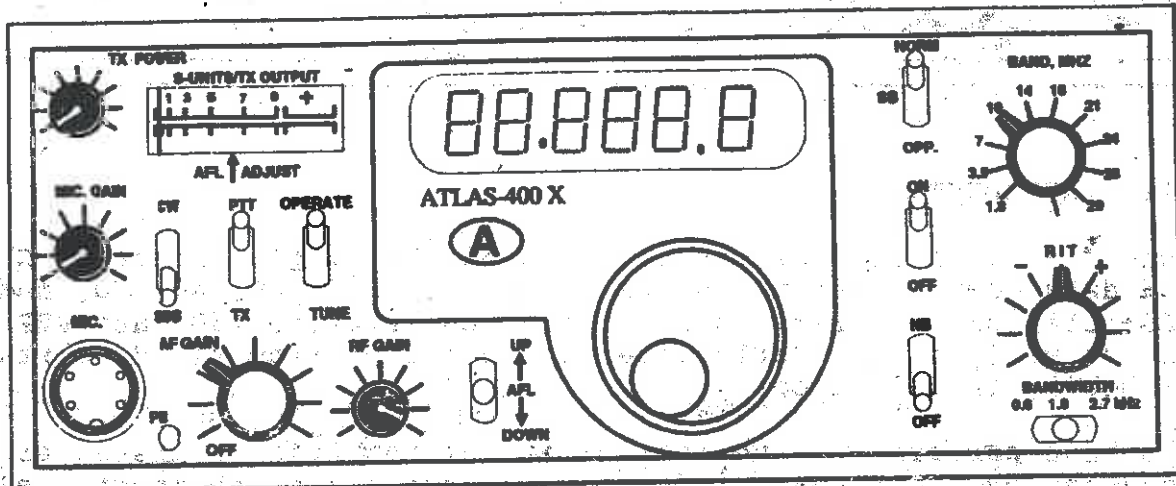

ATLAS - 400X

SOLID STATE SINGLE SIDEBAND TRANSCEIVER

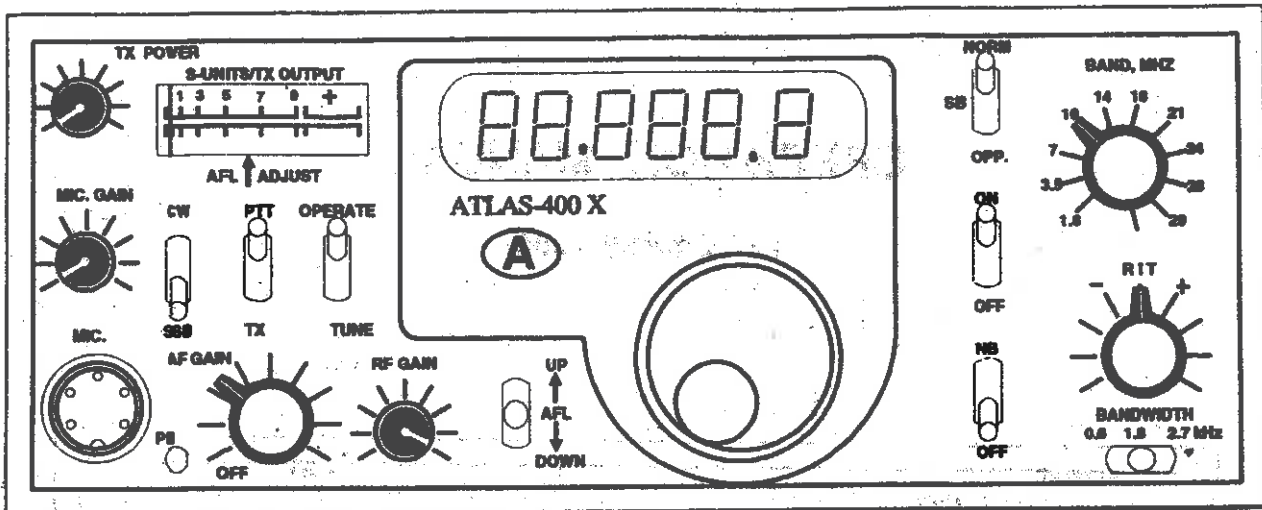

1-1. INTRODUCTION

The Atlas 400X Transceiver is designed for single sideband, CW, and data communications in the 10, 12, 15, 17, 30, 40, 80, and 160 meter amateur radio bands. The conservative 150 watt PEP output will provide world wide communication from fixed, portable or mobile installations.

The high performance and reliability of the Atlas transceiver is enhanced by the finest craftsmanship, and a most thorough quality control program. Our staff is made up of highly skilled assembly workers, technicians, and engineers, many of whom are active radio hams. Our service department, if and when needed, is dedicated to making every Atlas owner a satisfied customer. Speaking for all the gang at Atlas Radio, we wish you many hours of operating pleasure with you Atlas transceiver.

73 Herb Johnson W6QKI
Chairman of the Board
ATLAS Radio Company

GENERAL SPECIFICATIONS

BAND COVERAGE:

160 m Band	1.8 to 2.0 MHz
80 m Band	3.5 to 4.0 MHz
40 m Band	7.0 to 7.3 MHz
30 m Band	10.1 to 10.2 MHz
20 m Band	14.0 to 14.4 MHz
17 m Band	18.0 to 18.2 MHz
15 m Band	21.0 to 21.5 MHz
12 m Band	24.6 to 25.2 MHz
10 m Band(1)	28.0 to 28.7 MHz
10 m Band(1)	28.6 to 29.7 MHz

MODES: LSB (J3E), USB (J3E),
CW (A1A), AFSK (F1B)

FREQUENCY CONTROL:

Highly stable VFO common to both receive and transmit modes with two speed tuning control. The VFO is stabilized by our Automatic Frequency Lock (AFL). Band switching is accomplished with pin diodes.

FREQUENCY READOUT:

Six digit LED display providing frequency readout to within 100 Hertz.

EXTERNAL FREQUENCY CONTROL:

Rear socket provides for plug-in of external VFO or crystal oscillator accessory for separate control of transmit and receive frequencies, or for network and MARS operation. Accessories will be available for expanded coverage in 1995.

CIRCUIT DESIGN:

All solid state single conversion with 5595 kHz IF.

PLUG-IN DESIGN:

Transceiver plugs into the Deluxe Mobile Mounting Bracket, or into the ATLAS

400PS power supply console, making transfer or removal a simple operation. All connectors are standard: SO-239 antenna jack, CW key, external speaker or headphones, and linear amplifier control.

POWER REQUIREMENTS:

12 TO 14 VDC, negative ground

CURRENT DRAIN:

Receive - 0.5 A

Transmit - up to 22 A

Average with SSB modulation will be approx. 8 A.

Optional plug-in AC POWER SUPPLY CONSOLE available.

ANTENNA IMPEDANCE: 50 ohms

WEIGHT: 7 lbs (3.2 kg)

DIMENSIONS inches:

9 wide, 3.5 high, 9 deep.

RECEIVER SPECIFICATIONS

CIRCUIT DESIGN: Front end design provides exceptional immunity to overload and cross modulation. Signals are converted directly to the 5595 kHz IF without preamplification. Converter and product detector are double balanced diode rings. IC's are employed in IF and AF stages.

SENSITIVITY: Requires less than 0.4 microvolts for a 10 dB signal-plus-noise to noise ratio on all bands.

SELECTIVITY: Bob Crawford has designed a custom eight pole crystal filter with switchable bandwidth 0.6 kHz for CW, 1.8 kHz for narrow SSB, and 2.7 kHz for normal SSB, with Shape Factor of 1.4 (6 to 60 dB).

IMAGE REJECTION: More than 60 dB.

INTERNAL SPURIOUS: Less than equivalent 1 microvolt signal.

AGC CHARACTERISTICS: Audio output constant within 4 dB with signal variation from 5 microvolts to more than 3 volts.

OVERALL GAIN: Requires less than 1 microvolt signal for 0.5 watts audio output. (CW carrier, 1000 Hertz heterodyne).

AUDIO FIDELITY: 300 to 3000 Hertz, plus or minus 3 dB.

INTERNAL SPEAKER: 3 in., 3 ohm, .68 oz. magnet. Rear jack permits plug-in of external speaker, or high impedance headphones. When transceiver

is plugged into the AC power supply console the front facing speaker on console becomes operative.

METER: Reads "S" units from 1 to 9, plus 10 to 50 dB over S-9. Also reads AFL voltage when adjusting the AFL control.

RIT CONTROL: Plus and minus 10 kHz.

MODEL ATLAS-400PS POWER SUPPLY CONSOLE SPECIFICATIONS

INPUT VOLTAGE: Power supply operates on 120 volt or 240 volt AC, 50 or 60 Hz. Selected by removing rear panel and inserting fuses into the proper clips. (Power supply shipped in 120 volt configuration).

INPUT POWER: 10 watts average in receive mode. 300 watts transmit peak.

OUTPUT: Low current line: 13.6 volts regulated, $\frac{1}{2}$ A.
High current line: 13.6 volts at 22 A.

SPEAKER: 4 in. 1.1 oz magnet, 4 ohm voice coil.

PLUG-IN DESIGN: Transceiver plugs directly into power supply console, automatically makes connections for antenna and front facing speaker. Headphone jack and CW key are brought out to front panel.

DIMENSIONS inches: 15 $\frac{1}{2}$ wide, 7 high, 9 $\frac{1}{2}$ deep.

WEIGHT: 14 $\frac{1}{2}$ lbs less transceiver.

TRANSMITTER SPECIFICATIONS

CIRCUIT DESIGN: Broadband design eliminates transmitter tuning. Single conversion from IF to output frequency produces minimum spurious and mixing products. Two section low-pass filters on each band provide harmonic suppression equal to commercial standards.

EMMISSION: With the SSB selector switch in NORMAL position operation will be lower sideband on bands below 14 MHz and upper sideband on the 14 MHz band and above.

POWER RATING: 150 watts PEP output on SSB, and 120 watts CW output, (with 50 ohm resistive load and 13.8 volt D.C. supply) on 160, 80, 40, 30, and 20 meter bands and somewhat less on the higher frequency bands.

RTTY POWER RATING: Approximately 90 watts PEP output (dependent directly on ventilation of heat sink).

TRANSMIT CONTROL: Press-to-talk with Mic. button, or manual transmit with Function Switch on front panel.

CW KEYING: Semi-break-in.

UNWANTED SIDEBAND: More than 60 dB down at 1000 Hertz AF input.

CARRIER SUPPRESSION: More than 60 dB down.

THIRD ORDER DISTORTION: Approximately 30 dB below peak power.

HARMONIC OUTPUT: More than 40 dB below peak power.

SPURIOUS AND IMAGE OUTPUT: More than 40 dB below peak power.

AUDIO FIDELITY: 300 to 3000 Hertz, plus or minus 3 dB.

METER: Reads relative power output.

LINEAR AMPLIFIER CONTROL: Rear auxillary connector provides for keying of linear.

MICROPHONE: Dynamic or crystal. Plug requirement: Five pin connector.

2-1. OPERATING CONTROLS

2-1-1. Front Panel

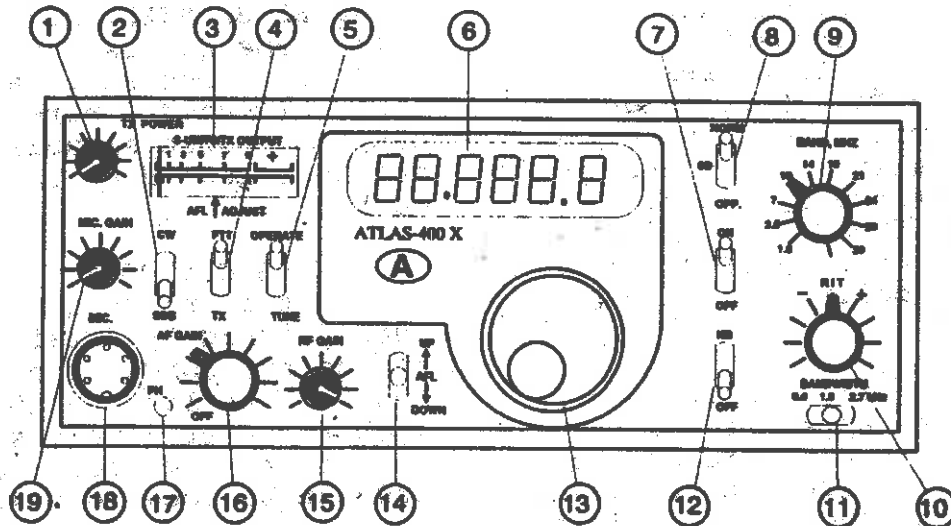

1 TX POWER control

Output power can be adjusted from 150 watts PEP down to 5 watts PEP.

2 CW/SSB switch

In the CW position, the carrier will be transmitted 800 Hz above or below the indicated receive frequency depending on the selected frequency band. When transmitting, the actual transmit frequency will be displayed. In SSB position the display frequency represents the position of the suppressed carrier during both transmit and receive.

3 Meter

During receive the meter is normally used as an S-meter. It can also indicate the Automatic Frequency Lock (AFL) voltage when the AFL switch is activated. During transmit the meter is used to indicate relative output power.

4 PTT/TX switch

In the PTT position, the microphone push-to-talk switch must be pressed to activate the transmitter. In the TX position, the transmitter is immediately activated.

5 OPERATE/TUNE switch

This switch should normally be in the OPERATE position. The TUNE position activates a CW carrier permitting adjustment of the transmitter output power and allowing low power antenna tuner adjustments.

6 Frequency display

The operating frequency is displayed to the nearest 100 Hz. With RIT ON, the frequency displayed is the transmit frequency during transmit and the receive frequency during receive.

7 RIT switch

This switch allows the receive frequency to be displaced from the transmit frequency. In the OFF position, normal transceiver operation occurs in which the transmit and receive frequencies remain equal. In the ON position, the transmit frequency remains as originally set and the receive frequency can be displaced from the transmit frequency up to plus or minus 10 kHz by positioning the RIT control.

8 SIDEBAND (SB) switch

Selects the upper or lower sideband for both transmit and receive. On frequencies below the 14 MHz band NORMAL selects the lower sideband and OPPOSITE selects the upper sideband. On frequencies in the 14 MHz band and above NORMAL selects the upper sideband and OPPOSITE selects the lower sideband.

9 BAND switch

The nine amateur bands between 1.8 MHz and 30 MHz can be selected by this switch. The 10 meter band has two positions.

10 RIT control

With the RIT switch in the ON position, the RIT control can displace the receive frequency by plus or minus 10 kHz relative to that of the transmit frequency.

11 BANDWIDTH switch

This switch selects one of three IF filter bandwidths, 0.6 kHz, 1.8 kHz, or 2.7 kHz. The 2.7 kHz position is best used for SSB operation. The 1.8 kHz position will cut the upper audio frequencies and be

useful in crowded band conditions. The 0.6 kHz position will give excellent results on CW.

12 NOISE BLANKER (NB) switch

Pulse type noises, such as ignition noise will be effectively silenced. More continuous type noise signals will not be silenced or reduced as much.

13 TUNING dial (VFO)

Tuning the transceiver is accomplished by rotating one of the two concentric tuning knobs. The large aluminum knob tunes at a rate six times that of the smaller black knob and can be used to move rapidly within the selected band. Use the smaller black knob for final frequency setting.

14 AFL UP/DOWN switch

The Automatic Frequency Lock (AFL) switch provides a means to reset the AFL offset voltage. When the AFL UP/DOWN switch is put into either the UP or DOWN position, the AFL voltage is shown on the S-UNITS/OUTPUT meter. If the AFL voltage reads either full scale or zero scale, the AFL UP/DOWN switch must be used to reset the AFL voltage to the indicated AFL ADJUST point located below the meter scale. If the AFL indication is above the AFL ADJUST mark, press the AFL switch DOWN until the meter is at the AFL ADJUST mark. If the AFL voltage is below the mark press the switch UP. After setting the AFL voltage the AFL switch must be returned to the center position. With the switch in the center position the meter will return to the S-meter function. The receiver fre-

quency will have to be slightly adjusted with the tuning knob after the AFL voltage has been reset.

15 RF GAIN control

This control adjusts the gain of the receiver high frequency stages. Normally it should be left in the full clockwise position, but some receiving conditions may be improved by turning the RF gain control down (counter-clockwise).

16 AF GAIN control/POWER OFF switch

Adjust the AF gain control for a comfortable audio level. When rotated fully counter clockwise, the transceiver will be turned off.

17 PHONES (PH) jack

Output terminal for headphones, 3.5 mm size.

18 MIC jack

Connector for a microphone.

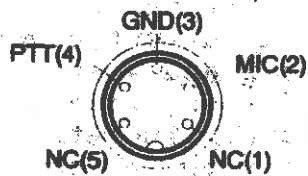

FRONT PANEL VIEW

19 MIC GAIN control

Microphone gain can be adjusted during USB, LSB, and AFSK modes. Gain is increased with clockwise rotation.

2-1-2. Rear Panel

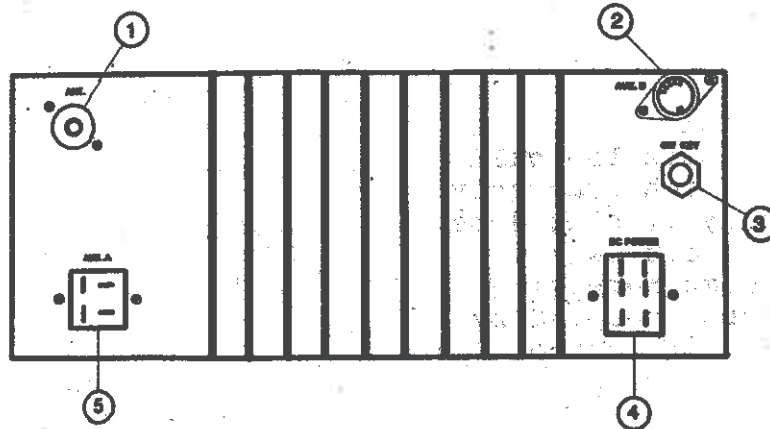

1 ANT (Antenna) connector
 Sending and receiving antenna connection. The antenna coax cable should be 50 ohm coax terminated with a PL-259 connector.

2 AUX. B (Auxiliary) connector

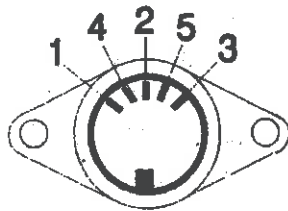

REAR PANEL VIEW

Pin No.	Pin Name	Application
1	INT. VFO	400X VFO signal
2	GND	Ground
3	+10 VDC OUT	Internal 10V reg.
4	OSC. IN.	400X VFO or extern. oscillator
5	VFO +10V	Power to 400X VFO

3 CW KEY connector
 Using shielded line, connect a 1/4 inch phone plug to this jack for CW operation. Open-terminal voltage is approximately 13 VDC and a short circuit current of about 40 ma.

DC POWER

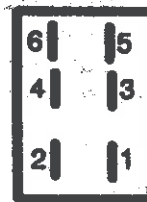

REAR PANEL VIEW

AUX. A

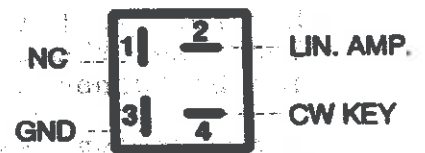

REAR PANEL VIEW

4 DC power connector
 Used to connect the DC power supply and external speaker. Pins 5 and 6 are parallel positive high current connections. Pins 3 and 4 are paralleled for negative and chassis ground. The Atlas Model 400-PS supplies positive 13 volts regulated to pin 1. For battery operation, the positive supply should be applied to pins 1, 5 and 6 in parallel. Supply voltage should be 13.8 VDC for rated output power. Supply voltage should be kept between 12 VDC and 16 VDC. Pin 2 is used for an external speaker.

3 AUX. A (Auxiliary) connector
 Provides external connections for CW key and Linear Ampl.

2-2. RECEIVE

2-2-1. Initial setting

1. Preset the controls as follows:

AF GAIN control fully counter-clockwise to the OFF position.

RF GAIN control fully clockwise.

CW/SSB switch to SSB.

PTT/TX switch to PTT.

OPERATE/TUNE switch to OPERATE.

RIT switch to OFF.

SB select switch to NORM.

BANDWIDTH switch to 2.7 kHz.

AFL UP/DOWN switch to center position.

2. Turn on the power by rotating the AF GAIN control clockwise and set it for the desired volume.

3. The S-meter will illuminate and a frequency will appear on the FREQUENCY DISPLAY.

4. Rotate the BAND switch to the desired band.

5. Using the TUNING KNOB, select the desired receive frequency. The large aluminum tuning knob is used for rapid frequency changes, the smaller black tuning knob is used for fine tuning.

6. The NORMAL position of the SIDEBAND SELECT (SB) switch will result in lower sideband (LSB) for frequencies below

the 14 MHz band and upper sideband (USB) for frequencies in the 14 MHz band and above. If the opposite sideband is desired, place the SIDEBAND SELECT switch in the OPPOSITE position. If OPPOSITE sideband is selected the BANDWIDTH switch should be kept in the 2.7 kHz position.

2-2-2. CW reception

1. Place the CW/SSB switch in the CW position.

2. Place the SIDEBAND SELECT (SB) switch in the NORMAL position.

Note: Operation in OPPOSITE sideband is not recommended for the CW mode.

3. Select the 1.8 kHz IF bandwidth with the BANDWIDTH switch which will allow faster signal location.

4. Slowly rotate the TUNING KNOB until the desired CW signal is heard and adjust the audio tone to about 800 Hz.

5. Select the 0.6 kHz IF bandwidth with the BANDWIDTH switch.

6. Peak up the signal on the S-meter with the TUNING KNOB. With the signal peaked in the 0.6 kHz IF filter the audio tone should be close to 800 Hz. With this setting the frequency indicated on the FREQUENCY DISPLAY should be 800 Hz above that of the transmitting station for

frequencies below the 14 MHz band and 800 Hz below for frequencies in the 14 MHz band and above.

2-2-3. Using RIT

Normal operation should take place with the RIT switch in the OFF position. This keeps both the receiver and transmitter on the same frequency. However if the station you are talking to drifts off frequency, or you are in a round table, you can move the receiver frequency for optimum reception while the transmitter remains at a fixed frequency. To do this, move the RIT switch to the ON position. You can now use the RIT control to offset the receiver from the transmit frequency by plus or minus 10 kHz.

2-3. TRANSMIT

2-3-1. SINGLE SIDEBAND (SSB) mode

1. Initially set the transmit power to minimum by rotating the TX POWER control fully counter-clockwise.

2. Place the mode switch in the SSB position.

3. For conventional sideband operation, place the SIDEBAND SELECT (SB) switch to the NORMAL position. This will result in lower sideband (LSB) operation for frequencies below the 14 MHz band and upper sideband (USB) operation for frequencies in the 14 MHz band and above.

4. Using the BAND switch and the TUNING KNOB, select the desired operating frequency.

5. If an external antenna tuner is to be used and the frequency is clear to transmit, place the OPERATE/TUNE switch in the TUNE position. This will transmit a steady carrier. It is normal for the displayed frequency to change slightly in TUNE mode. Adjust the TX POWER control if necessary and adjust the antenna tuner.

6. After antenna tuning is complete, return the OPERATE/TUNE switch to the OPERATE position.

7. Rotate the TX POWER control to the full clockwise position.

8. Press the microphone PTT switch or place the PTT/TX switch in the TX position.

9. Speak into the microphone and adjust the MIC. GAIN until the reading on the S-UNITS/TX OUTPUT meter averages 50% of full scale. Do not exceed 75% meter reading on voice peaks or distortion of the transmitted signal can occur.

10. Once the MIC. GAIN has been set, the TX POWER control can be rotated counter-clockwise to reduce transmitted output power as conditions permit.

2-3-2. CW mode

1. Initially set the transmit power to minimum by rotating the TX POWER control fully counter-clockwise.

2. Insert the CW sending key plug into the CW KEY jack on the rear of the transceiver or in the front of the 400PS console if in use.

3. Place the mode switch in the CW position.

4. Place the SIDEBAND SELECT (SB) switch in the NORMAL position.

5. Using the BAND switch and the TUNING KNOB, select the desired operating frequency.

6. If an external antenna tuner is to be used and the frequency is clear to transmit, place the OPERATE/TUNE switch in the TUNE position. This will transmit a steady carrier. It is normal for the displayed frequency to change slightly in TUNE mode. Adjust the TX POWER control if necessary and adjust the antenna tuner.

7. After antenna tuning is complete, return the OPERATE/TUNE switch to the OPERATE position.

8. Send a series of dots while at the same time slowly increase the TX POWER control until a level of 50% full scale is indicated on the S-UNITS/TX OUTPUT meter.

Automatic transmit/receive change-over are built into the Atlas 400X for semi break-in operation. The first dot or dash sent by the CW key will cause the T/R switch to switch to the transmit state and transmission will begin. After a period of about two seconds following the last keyed transmission the T/R

relay will change back to the receive state.

NOTE: The Atlas 400X provides a sidetone oscillator which produces an 800 Hz tone in the speaker when the transmitter is keyed in the CW mode.

2-4. RTTY OPERATION

2-4-1. Reception

RTTY requires Audio Frequency Shift Keying (AFSK) while in the SSB mode. This means the Atlas 400X must be supplied audio tones of approximately 2125 and 2295 Hz. By convention these modes use lower sideband (LSB) on all bands. However, the Atlas 400X will allow either LSB or USB modes in transmit and receive.

1. Place the CW\SSB switch to SSB.

2. For frequencies below the 14 MHz band use the NORMAL sideband for LSB reception. For the 14 MHz and above, LSB operation requires placing the SB select switch to OPPOSITE.

The 0.6 kHz filter will not be properly aligned for RTTY tones in either NORMAL or OPPOSITE sideband modes and should not be used.

3. For proper reception of RTTY signals, use only the 2.7 kHz bandwidth for frequencies below the 14 MHz band. For frequencies in the 14 MHz band and above, either the 1.8 or 2.7 kHz bandwidths can be selected.

4. Tune to an RTTY station and fine tune using the indicator on the RTTY terminal device. The audio tones should be centered around 2210 Hz.

2-4-2. Transmission
RTTY transmissions are continuous and will require a reduction of power to keep the output transistors from overheating. Monitor the heat sink with your fingers. If you can stand to keep your fingers on the heat sink you are not going to damage the unit.

1. Initially set the transmit power to minimum by rotating the TX POWER control fully counter-clockwise.

2. The CW/SSB switch should be in the SSB position and the RTT switch should be in the OFF position.

3. Set the SIDEBAND SELECT (SB) switch to NORMAL on frequencies below the 14 MHz band or to OPPOSITE for frequencies in the 14 MHz band and above.

4. If an external antenna tuner is to be used and the frequency is clear to transmit, place the OPERATE/TUNE switch in the TUNE position. This will transmit a steady carrier. It is normal for the displayed frequency to change slightly in TUNE mode. Adjust the TX POWER control if necessary and adjust the antenna tuner.

5. After antenna tuning is complete, return the OPERATE/TUNE switch to the OPERATE position.

6. Rotate the TX POWER control to the full clockwise position.

7. Begin transmitting on RTTY and rotate the MIC. GAIN until the reading on the OUTPUT meter reads between 30-40% of full scale.

DRAFT

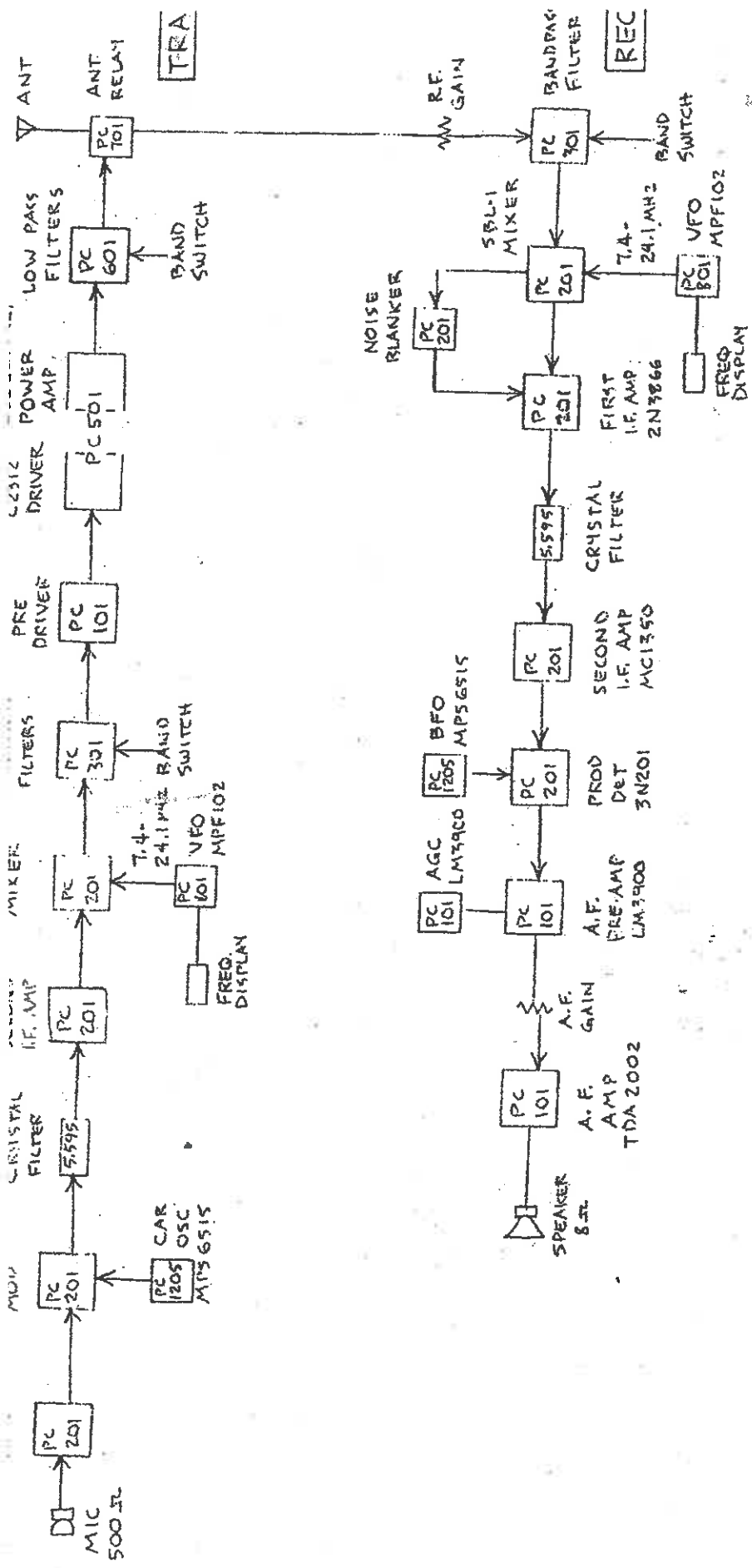

ATLAS MODEL 400-X BLOCK DIAGRAM

- 3. 7,000 = 12,595
- 10,000 = 15,595.00
- 18,000 = 12,405.00
- 21,000 = 15,406.00
- 25,000 = 19,406.00

28,000 = ?

PCB's (400X)

PC101	R.F. ASSY
PC201	I.F. ASSY
PC301	BANDPASS FILTER (4) A, B, C, D.
PC410	PANEL SWITCH ASSY - LONG
PC420	PANEL SWITCH ASSY - SHORT
PC501	DRIVER / POWER AMP
PC601	LOW PASS FILTER (5) A, B, C, D, E
PC701	ANT RELAY
PC801	VFO OSC, A.F.L
PC850	VFO MIXER TUNING
PC901	FREQ COUNTER, DISPLAY
PC1105	CW SIDETONE
PC1205	BFO / CAR OSC (CRYSTAL BD)
PC1250	R.I.T
PC1305	CRYSTAL FILTER



DRAFT

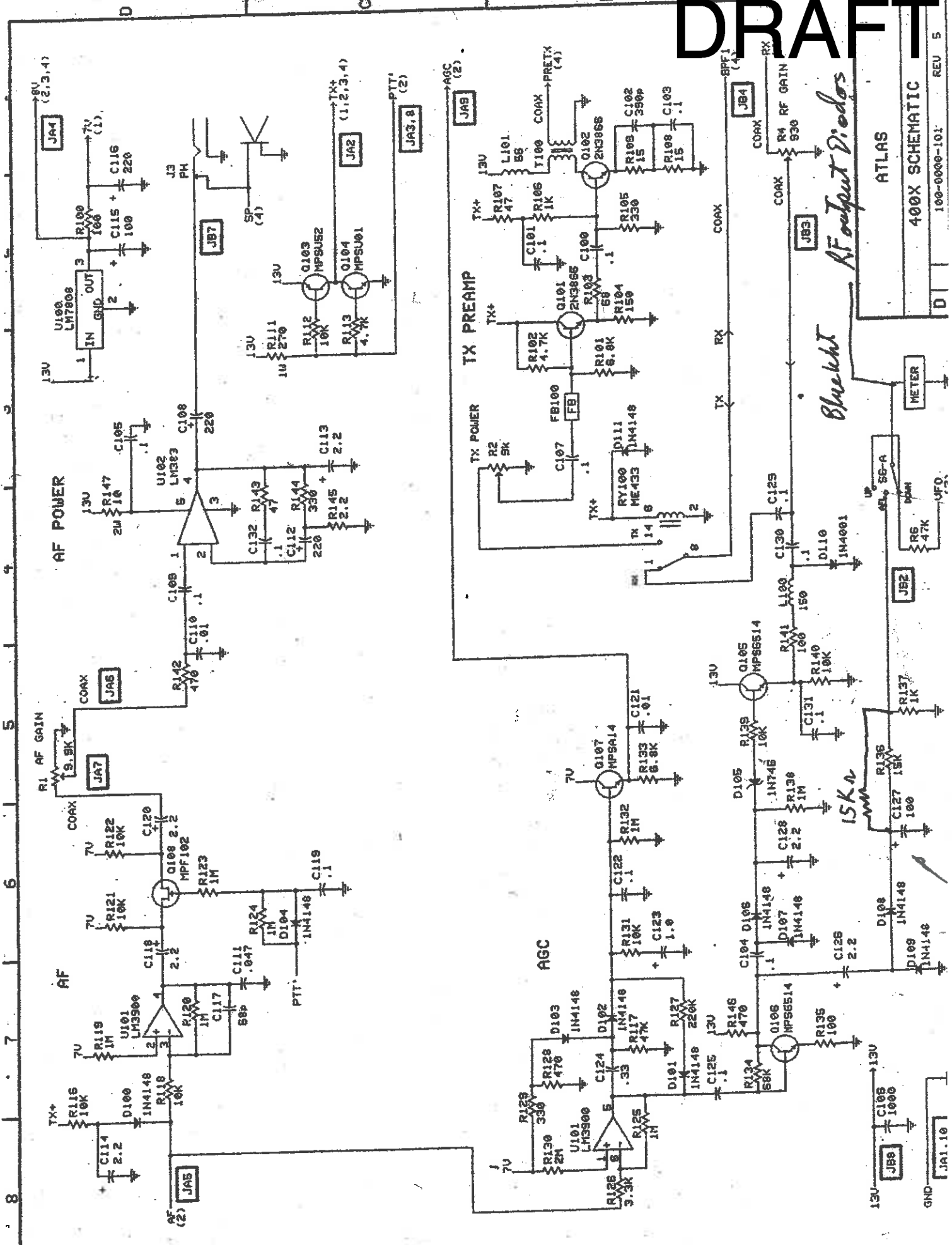

Bluebird AF output Diodes

ATLAS
400X SCHEMATIC

METER

REL. SE-A
DAM

47K

15K

100

100

100

1000

100

100

100

DRAFT

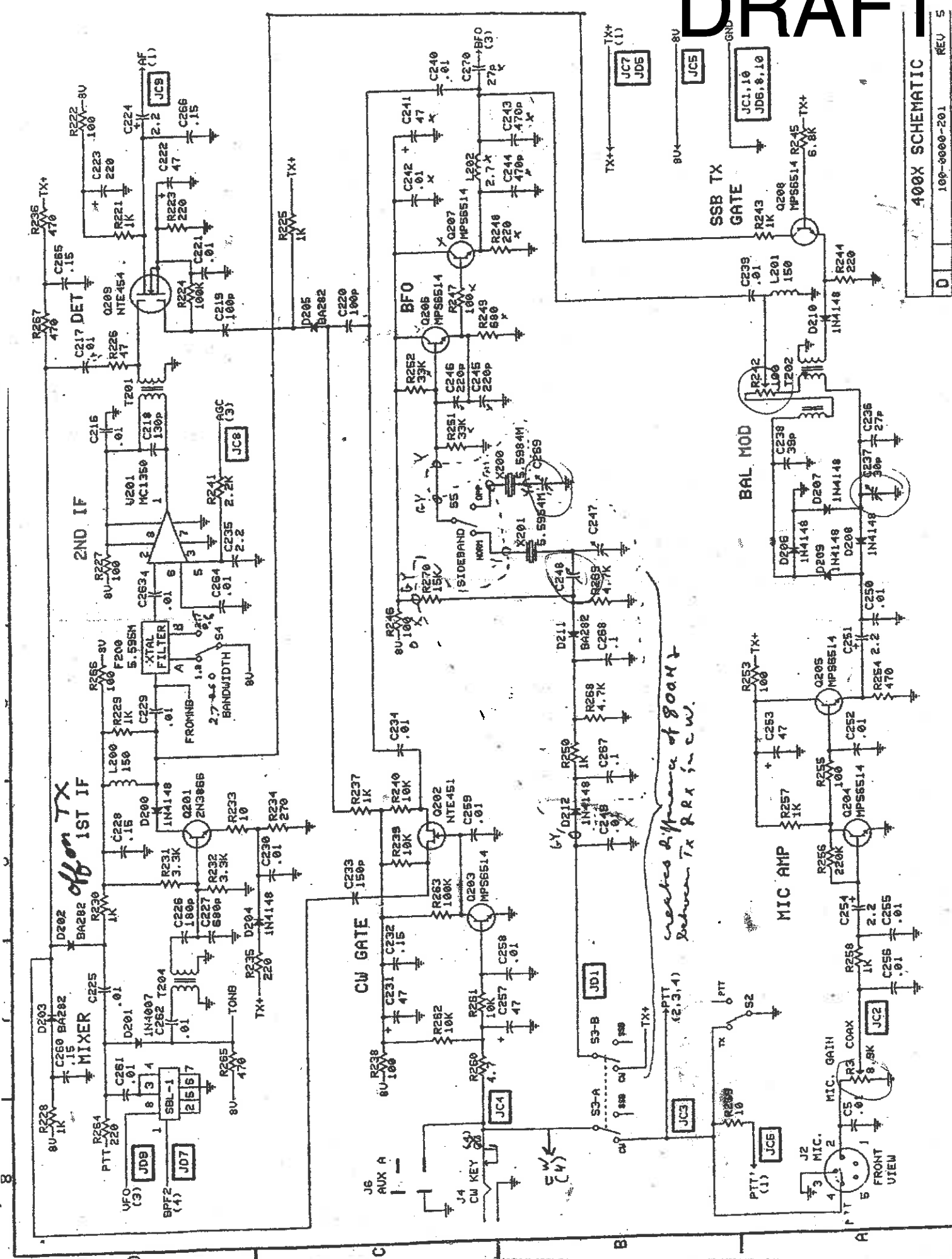

creates difference of 800M between TX & PTT in CW.

DRAFT

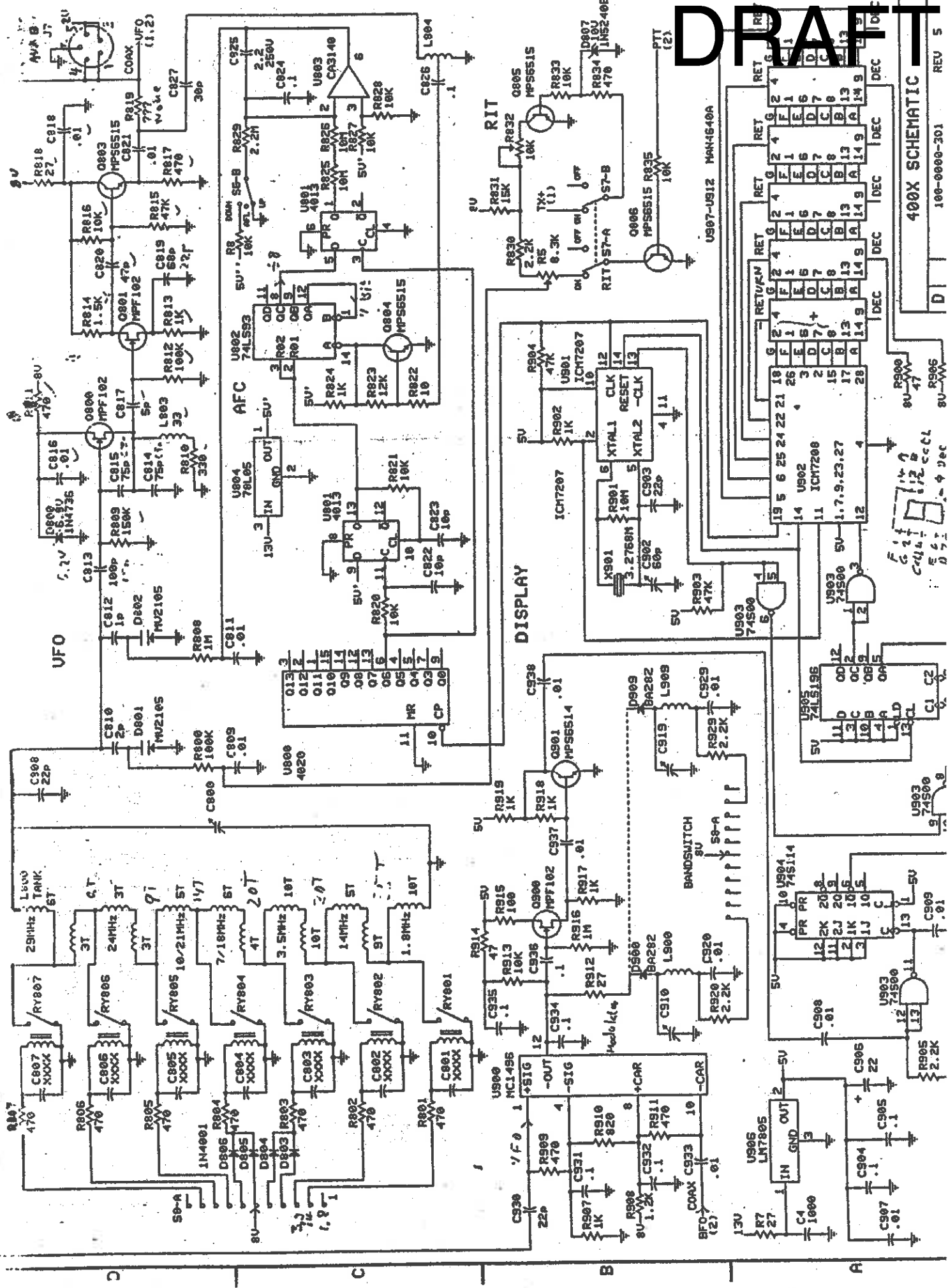

REV 5
100-0000-301

400X SCHEMATIC

D

5 4 3 2 1
C444
1.4
1.2
1.1
1.0
0.9
0.8
0.7
0.6
0.5
0.4
0.3
0.2
0.1

U900 74500
U901 74500
U902 74500
U903 74500
U904 74514

U905 745195
U906 745114

U907 74500
U908 74500
U909 74500

U910 74500
U911 74500
U912 74500

U913 74500
U914 74500
U915 74500

U916 74500
U917 74500
U918 74500

DRAFT

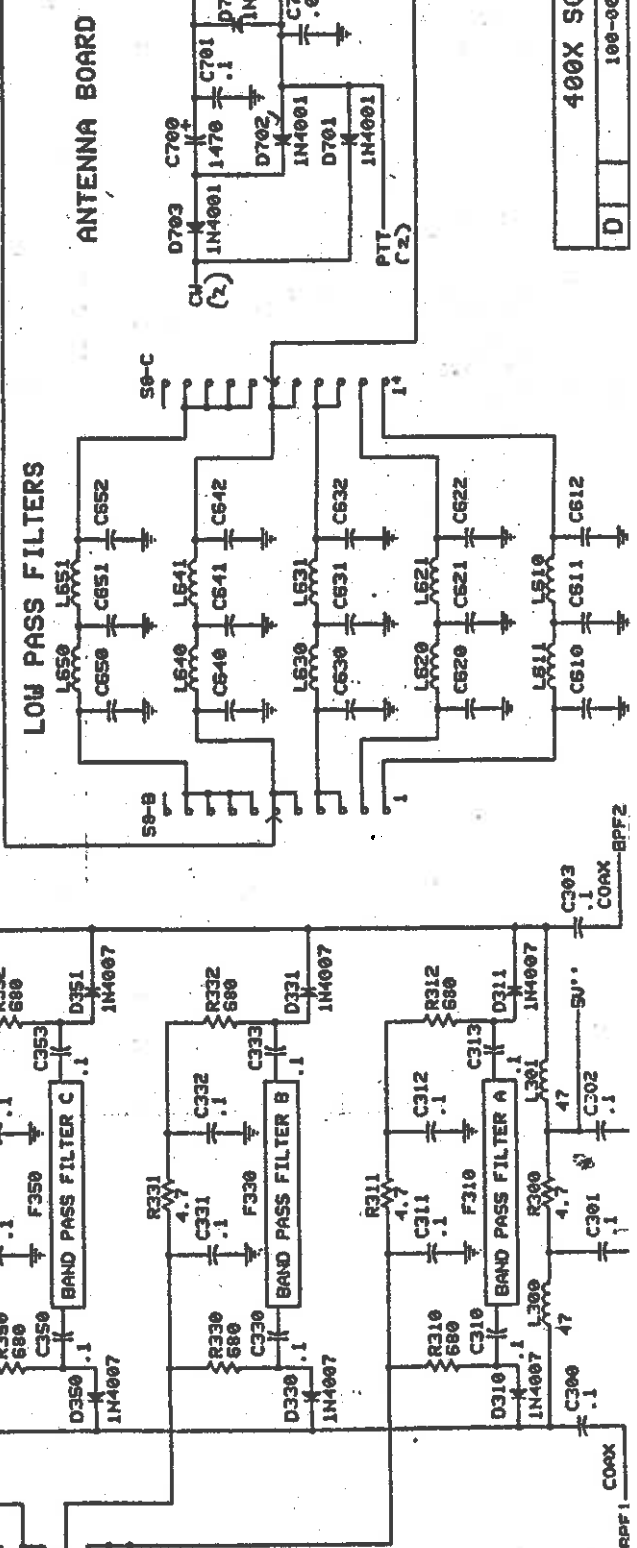
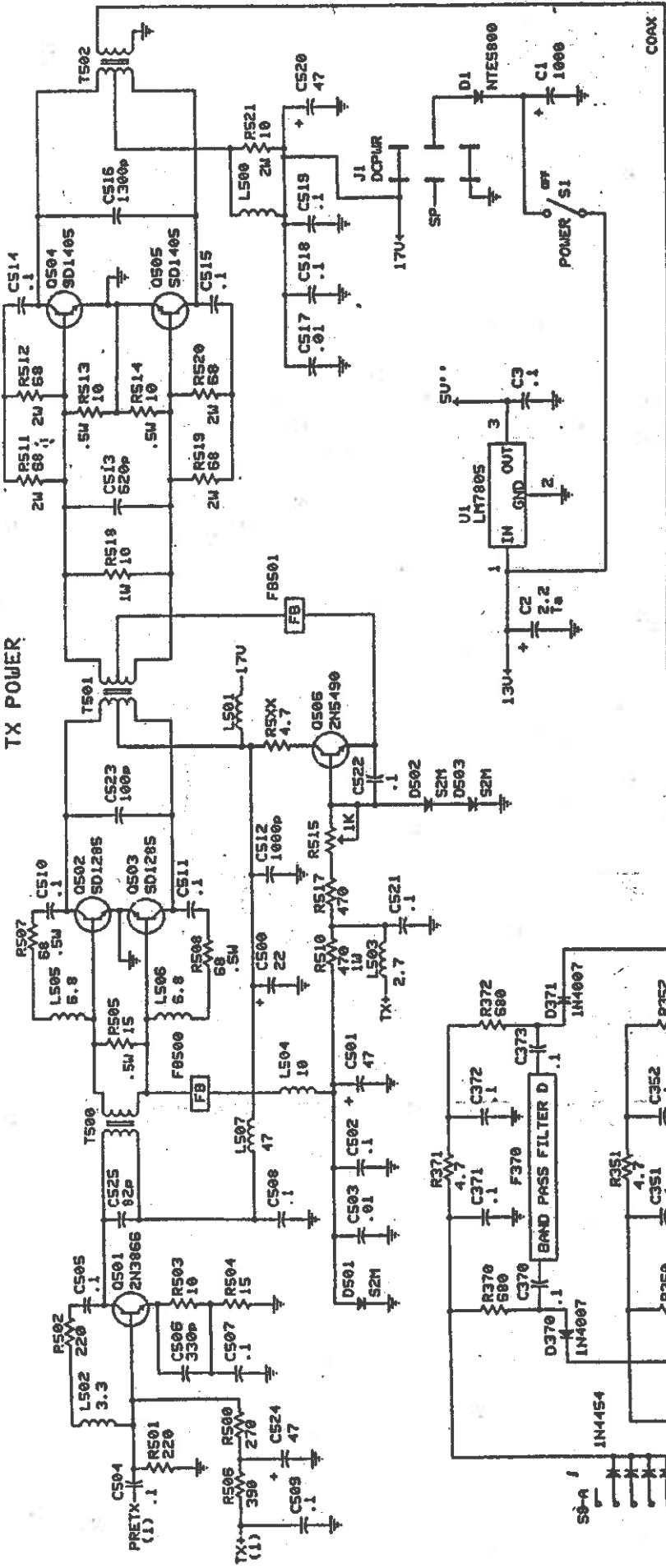

DRAFT