

Specialty

ATLAS RADIO NEWSLETTER

Communications

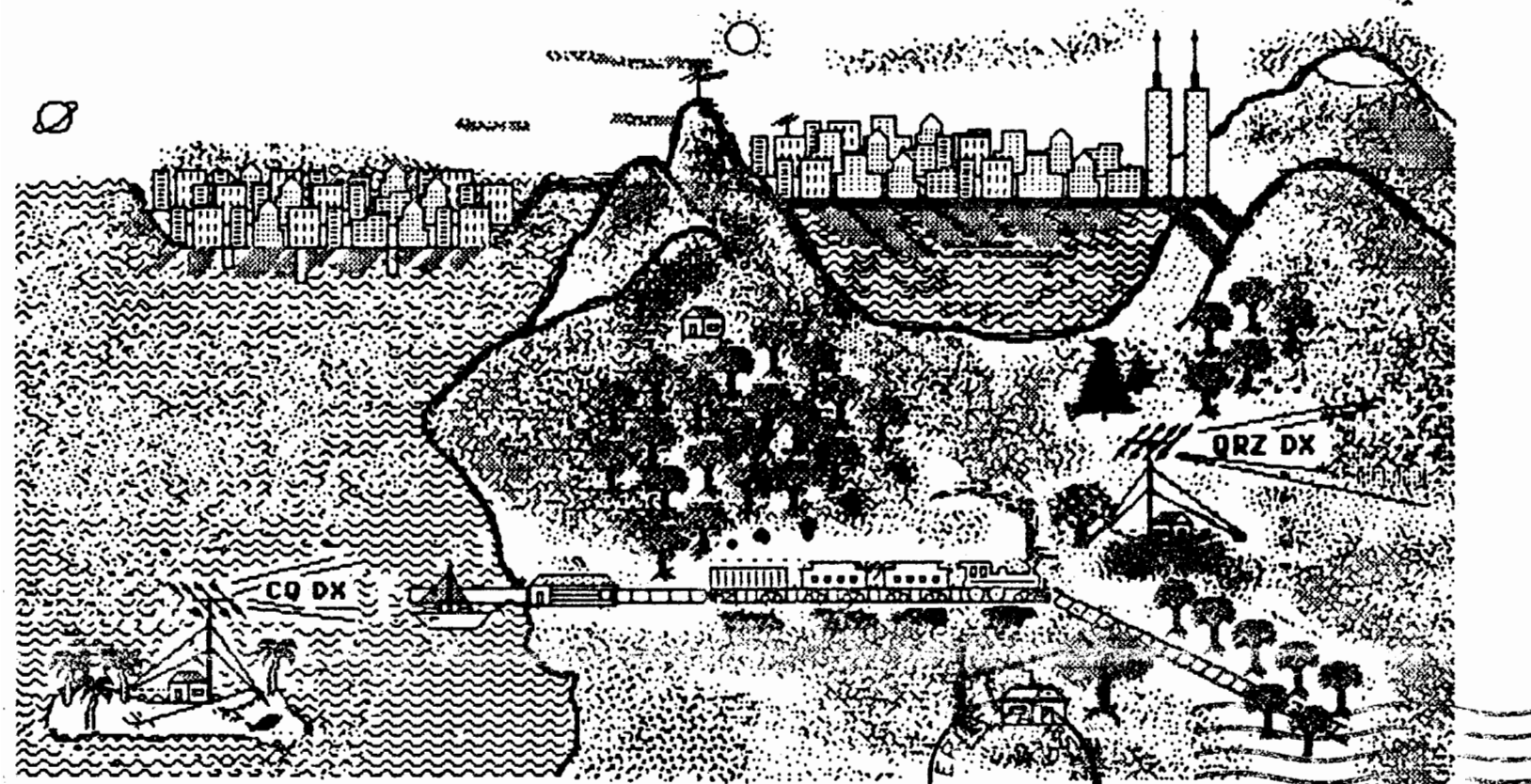

SPECIALTY COMMUNICATIONS
Steve Crossman
934 East 9th Street
ERIE, PENNSYLVANIA 16503



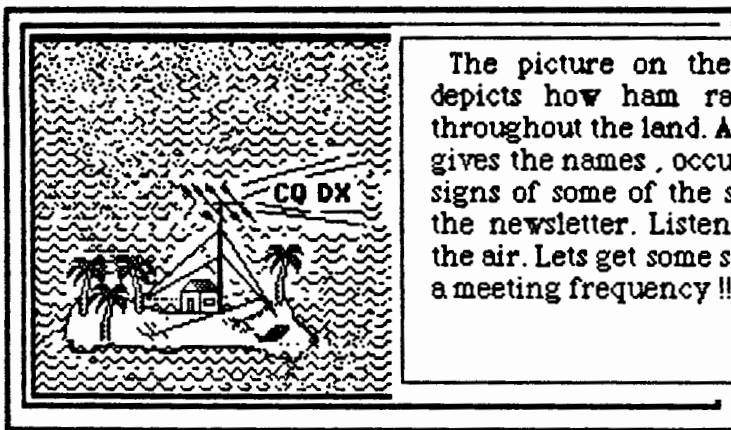

The picture on the front cover depicts how ham radio is found throughout the land. A listing inside gives the names, occupations & call signs of some of the subscribers to the newsletter. Listen for them on the air. Lets get some suggestions on a meeting frequency !!!!

Welcome to the **Atlas Newsletter**. I am glad to finally bring to press this newsletter. I conceived it many years ago and never had the right tools to do it with. However, since I purchased the new **Apple Macintosh Computer** I have been able to do the things I originally planned, without the expense of a commercial printer. Everything in the newsletter has been produced on the "Mac". I look forward to a bigger and better newsletter in the future. It will contain information on how you can align your radio. If you own a 210x, 215x, or 350x1, you will find helpful information on repairing and aligning your rig. Most of it has never been released before.

I see a need for the owners to know some vital things about their radios and not have to ship it across the country for minor repairs that they themselves can perform. Even knowing how to realign it would be helpful in eliminating minor problems in operation. The newsletter will contain some helpful information so save it and put it away for safe keeping, hopefully you will not need to use it. In 1983, the repair of the Atlas radios dropped considerably, I had to acquire a full-time job to support the family. I did not stop fixing the Atlas rigs, but it took alot longer for me to repair them, Then in early 1984, business boomed again and I was swamped with radios. So I must apologize to those who had to wait a long time for repairs to be completed. The structure of my business is a little different than it was several years ago. Before June 1983, **Specialty Communications** was a retail Ham store. I closed the store after the market slowed considerably. At that point I bought a house and have my shop located there. No longer do I have a repair technician and a secretary. So the wheels turn a little slower but the rigs do get fixed!

I look forward to meeting some of you on the radio. If you are active on RTTY, then leave a message in the MSO **WB4ZQB** on **7.087.8** MHZ 40m. Access code is **MSOZQB** and use HAL 3100 commands. Also, I am active on 7.258 Mhz, Mid-Cars Net on 40m SSB.

For upcoming issues I will need articles. I would like to hear of different places the 210x & 350x1 have been used. Either car, Camper, RV, Sail Boat, Dx'pedition whatever. I know that they are used all around the world in many different places. If you have any particular comments about the performance of the rig etc., I would like to hear them to include them in the newsletter.

Steve Crossman WJUCS

Rare Parts - Misc.-Tips

The Part # **5082-7300** which is the L.E.D. readout used in the digital dial for **DD6, DD6C & DD6X1** are no longer manufactured by **HP**. They have not been available for quite a long time. I am currently negotiating buying some from a company in California. They have a small amount that they are willing to sell me, since the machines they are used in are phased out. If you need a replacement let me know. I need to get a small quantity together before they will meet their minimum order cost.

When tuning a transmatch, be very careful not to use full power. The SWR protection is some times not quite fast enough to cut back the power before it has a chance to go into self-oscillation. If the ALC Control is turned on (Full CW), it will prevent power output from exceeding 50-60 % of full power output.

Q503 in the 210x, 215x, RCA 40582 is no longer manufactured. Some people have used a **EC0324** Sylvania Replacement. This will function, however, often times power output on 80m & 10m is 10 - 15% below normal. The best transistor to use is a **2SC799**, it works identical to the 40582 except it has a higher power dissipation rating, which is certainly acceptable. Don't overlook **L503** and resistors **R519 & R512** - 1.1 ohm going bad when the 40582 goes. Refer to the drawing in this issue of the newsletter. This part often goes bad from touching a ground wire to the exposed collector of **Q503** (see drawing).

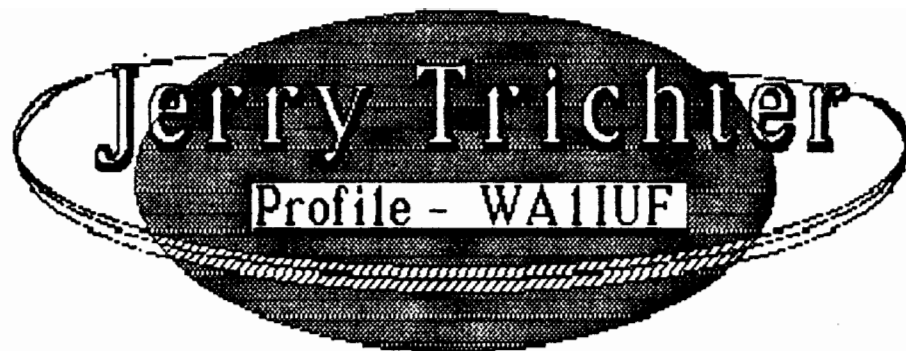

Jerry is a 58 year old accountant working in a large law firm in West Haven, CT and specializes in the settlement of Estates & Trusts. He is married and has three daughters and two grandchildren. Outside of his family and work Jerry devotes most of his time on computerized RTTY on 20m - 14.0975 Mhz. He has been on this frequency for the last 6 1/2 years using an Atlas 210x & the 10xb crystal oscillator. He runs a highly modified **Macrotronics M-8000** Mailbox System around the world and since going on microprocessed RTTY he has had over 300 users of his system. His Atlas 210x has been on the air 24 hours per day, 7 days a week with no serious downtime. He uses a 350XL as a backup for the 210x if needed. He is presently running a TRS-80, Model I with 48k and 3 disk drives. When Jerry is portable at Gardner Lake, Salem, CT in his travel trailer, he uses his 350xl with a Hal Telereader. Anyone is welcome to come up on frequency and use the systems listed below and each of them has their own access code. Watch for this group on 14.0975 MHZ and Jerry, as they welcome all to come aboard and join in on the oldest, longest running, 100 WPM RTTY group on the air.

<u>Call Sign</u>	<u>Name</u>	<u>Location</u>	<u>System</u>	<u>Access Code</u>
WA1IUF	Jerry	New Haven Ct.	Macro	IUFZW
WA1IURA/8	Frank	Traverse City, Mi	RBBS	:WA1IURA
WB7QWG/9	Bob	Indianapolis, In	Crown	QWGZW
W1CDM	Bernie	San Diego, Ca	Macro	CDMZW
KH6OD/5	Martin	Jackson, Ms	RBBS	:KH6OD
VK2HL	Horst	Dee Why, Aust.	Macro	VK2HLZW
ZF1GC	Frank	Grand Cayman	Crown	GCFZW
W1PW/6	Phil	California	Crown	PWZW
N1BLB/3	Ron	Philadelphia Pa	Crown	BLBZW
KA6CDC/4	Ray	Henderson, Ky	RBBS	:KA6CDC
W5VXF	Don	Houston, Tx	HAL	MSOVXF
K5QPT	Jim	Dallas, Tx	HAL	BOOMER
W90MV	Steve	Fond Du Lac, Wi	Macro	OMVZW
N1API	Al	Meriden, Ct.	HAL	MSOAPI

Comments & Suggestions

N3BJ - Alan Fryer - Erie, Pa. The 350xl is by far a superior receiver on the 40m, 80m & 160m. Japanese rigs were outperformed by the 350xl's quiet receiver. Seems it has a better Dynamic range enabling me to hear the DX better on the Atlas 350xl than the others that I have had on my bench during the last 18 years.

WA3UCR - Bill Trabold - Seems the 350xl power supply should have a protection circuit on the output to prevent damage in case of failure of the regulator or pass transistor. Recent Handbooks have shown such a circuit. It may be a wise idea to incorporate one into your rig.

My most famous customers here at Specialty Communications for repair of a Atlas 210x was **Marlon Brando**. As you may know he is a ham and he uses a 210x on his boat sailing around the world. The next most famous would have been **Barry Goldwater**, he also has a 210 & 220cs. - **WA3UCS**

350xl Oscillation Problem

Have you ever tried to use your **350xl** in **SSB** and when you push the **PTT**, all of a sudden the **Current Meter** jumps to full scale and the lights dim slightly and no power output is noticed? Well, you are not alone. This problem has plagued the **350xl** ever since its conception. Sometimes the fix is easy, other times it can be complicated !!!

First, locate the **PC-540 & PC-530** boards. These are the shown on page * **48** of your manual and in the picture below. If you tighten the screws mounting these boards, **90%** of the time the problem will go away. It is a good practice to tighten these screws occasionally as they will loosen during normal operation because of the heating & cooling of the power amplifier. Many times I have received radios here that had been repaired by someone else previously & they overlooked the simple solution. A good ground is essential on these boards so **ground - loops** don't develop in the low level transmitter circuitry. If this doesn't cure your problem then more troubleshooting is called for. Check **C505 22mfd** capacitor on **PC-540**. Many times this capacitor opens up from excess voltage or surges from the power supply. **Q532 CD3495** is sometimes at fault, not that often. It is also expensive to replace this driver transistor. At present it is still available through **RF Gain in New York** at a cost of \$ 38.00. However, their stock is limited to about 15 pieces left as of July 15, 1984.

If this problem is allowed to persist it may cause damage to the finals. In that event, repair costs can really mount up, so don't delay in getting it taken care of. Below is a drawing depicting where to tighten these crucial screws. Many times, when it is left to continue oscillating it will ultimately ruin the finals.

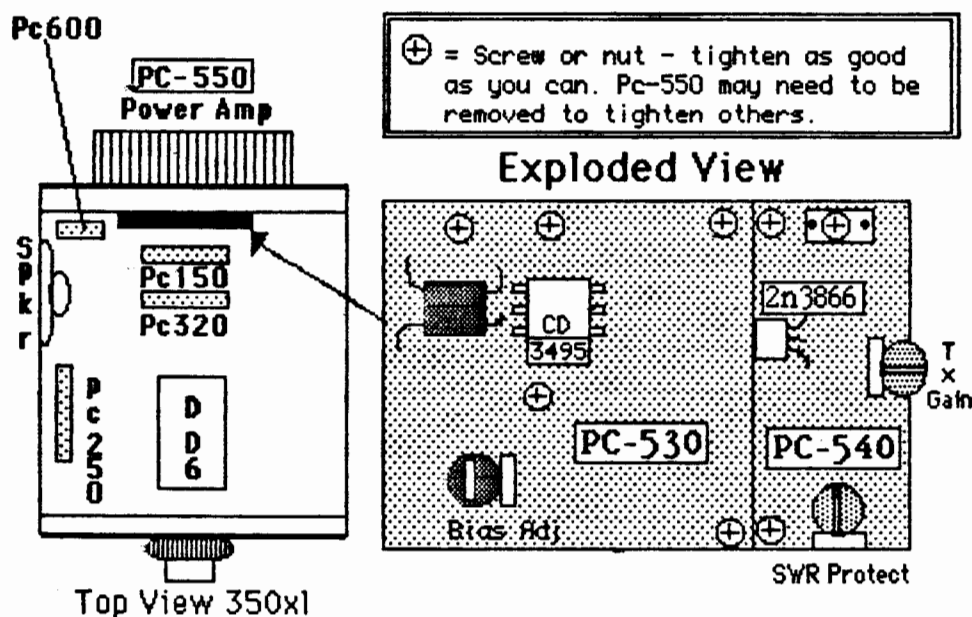

Use this drawing to also locate the **SWR protect adjustment**. The more clockwise you turn the adjustment the more protection you will have to a high **SWR**. The **TX Gain adjustment**, if turned full clockwise is at full. The **Bias Adjust** is for setting the power amplifier idling current to a pre-set level, it should read approximately 1 amp of current on the front panel meter with no modulation and hopefully no carrier. The carrier may be excessive and you may not be able to adjust the current in **SSB** with no modulation to read 1 Amp or .6VDC measure at the base of any of the final transistors.

210x , 215x Rear Chassis

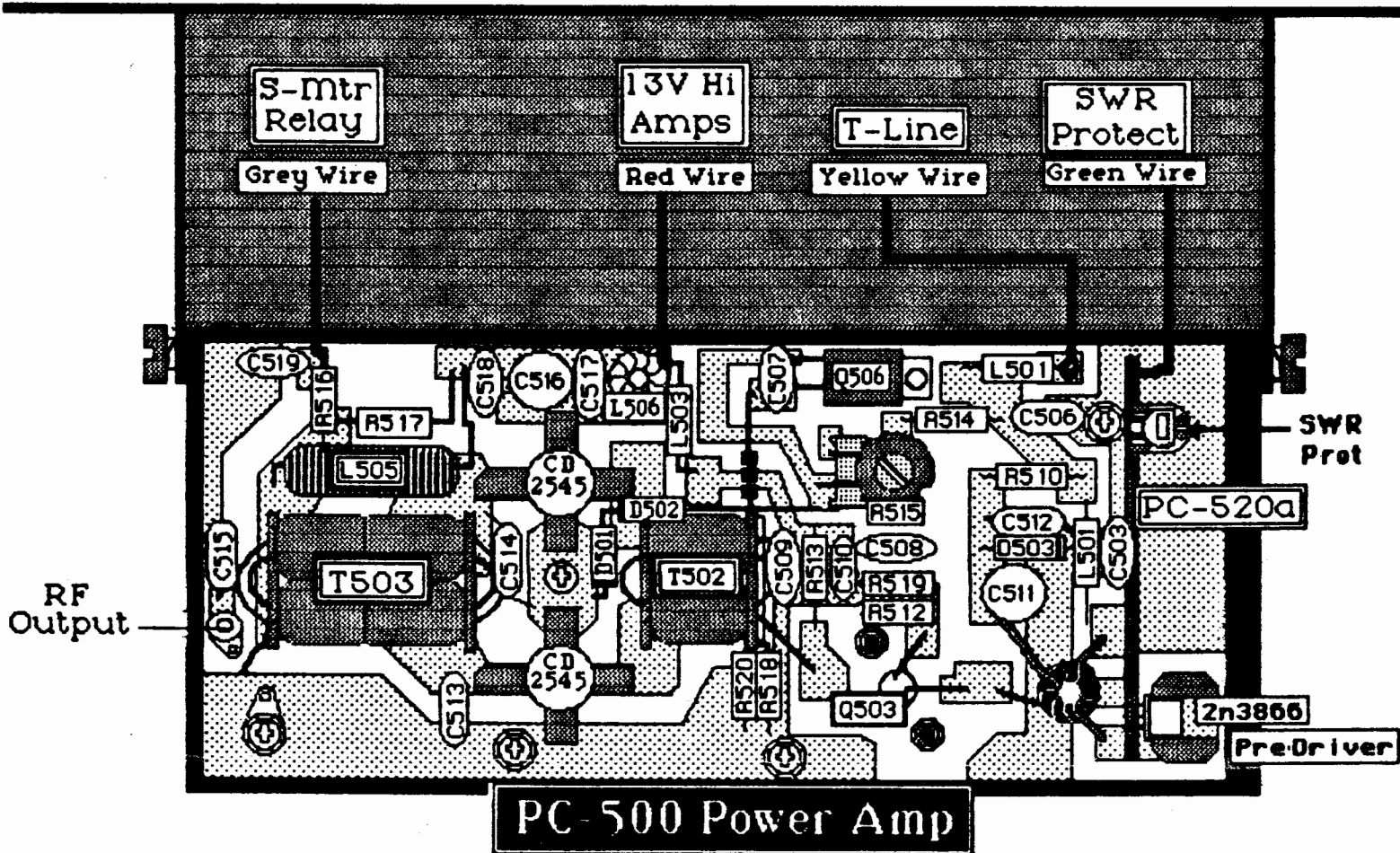

This picture represents a power amplifier for a 210x, the earlier models and 215x only vary slightly. Use it in conjunction with your operation manual and refer to the schematic for part numbers.

Common Problems :

- ➔ Loss of 13vdc to collector of Q503 - results in no output
Open L503 often results from shorting the case of Q503 or C509 or C510 shorting out.

Bad finals - R517 burned (4.7Ω) R520, R518 burned
R513 - burned. If any of these components are discolored it is a good indication of problems in the finals or overheating is occurring.

If you must replace the finals, they should be replaced with a final of higher power rating, such as the MRF458 from Motorola.

- ➔ R519 & R512 often open up. Use a ohm meter to check L503, R512 & R519, they should read as a dead short.
- ➔ R515 (large blue pot) is the Power Amp Bias adjust. R514 often opens leaving low bias voltage or R515 needs adjusted because bias is low, should be .6vdc at base of the finals, or read 1/2 amp on meter in transmit.
- ➔ Check for 13 vdc on T-Line when in transmit. If it is not present you will have no transmit. Often relay on PC-100 or PC-120 board is defective.

TOP View Chassis 210X & 215X

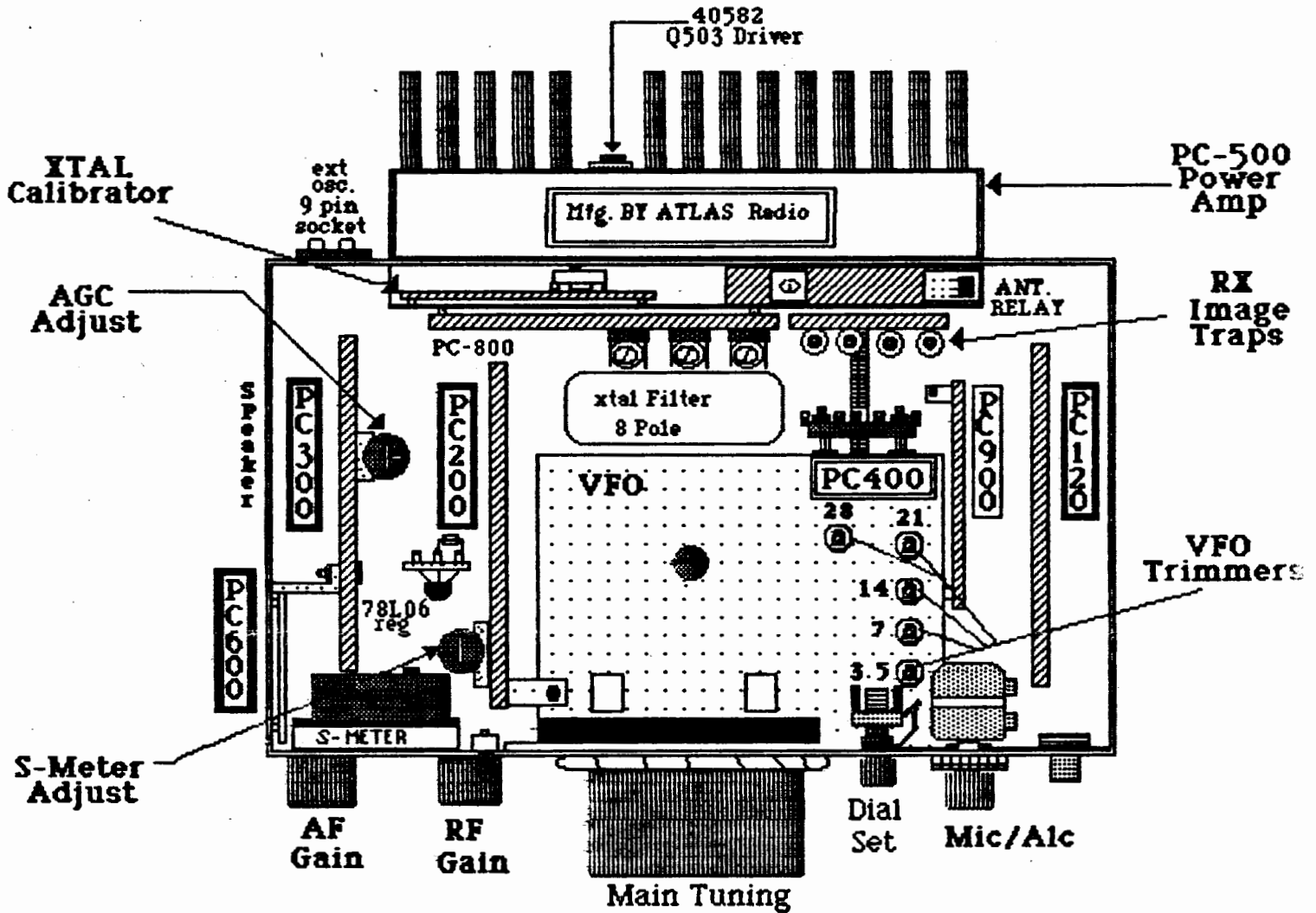

- PC-100 1st IF amplifier / mixer
- PC-120 1st IF amp/mixer/noise blanker
- PC-200 2nd IF amp/mixer s-mtr/speech amp
- PC-300 AGC / FET sw/ Audio Amp
- PC-400 VFO oscillator

Coming Next Issue



MacIntosh Computers

The mighty little Mac takes on all comers.

210x Alignments **DX Corner**

Flow charts & more schematics

350x1 - RIT Modifications

210x Power Amp Mod

40m MSO's for RTTY - Getting started on RTTY

RX - Tx 110 Alignments and Power-Amp Adj.



For Sale : Atlas 210x , 220cs power supply, MT-1 - Mobile matching Xmfr

Deluxe Mobile mounting bracket. Call Steve 814-455 -7674

Rx-110 Receiver 80m - 10m , excellent sensitivity

Call Steve 814-455 -7674

MFJ Phone Patch - never used - \$ 50 new - sell for \$ 15

Steve 814-455 -7674

For Sale : 215x — Pwr Supply — Mobile Mount — WB9QMR 414-425-0524

Wanted ——— DD6C digital dial for Atlas 210x - Art Lewis - WA8VSI

216-759-0208

Wanted 215x or Atlas 180 - Patrick O'Bryan - WB6USZ - 805-526-2818

Something to sell - Write to :

Specialty Communications 934 East 9th Street Erie , Pa. 16503
--

All listings are free to members, \$ 1 up to 50 words for any non members. Just send a dollar bill with listing of item to sell.

The following is a list of the new subscribers to the **Atlas Newsletter**. A few wished to be omitted. If you need to contact these individuals most are listed in the recent callbook or contact me, I can provide you with a phone number and address so you can reach them.

<u>Name</u>	<u>Callsign</u>	<u>State</u>	<u>Occupation</u>
Jerry Trichter	WA1UUF	Ct	Accountant
George Lehtinen	W81OC	Mi	Retired
John Topel	W900	U	Mfr's Rep.
Emeran Leonard	WB9QMR	Wi	Manager - Int.
Art Lewis	WA8VSJ	Oh	Real Est. Broker
Bill Neubauer Jr.	KC4ZZ	Va	Army Civilian
Ron Notarius	WN3VAW	Pa	Elec. Sales Rep.
Lloyd M ^c Cauley	K9AUK	U	Retired
Edmund Kendrick	KA1NS	Ma	Lawyer
Val Johnson	WA9DSJ	U	Material Analyst
Peter Clark	WA3QMK	Pa	Retired
Patrick O'Bryan	WB6USZ	Ca	Programmer
Earl Dridge	WB2GRB	Ny	Retired Teacher
George Goldstone	W8AP	Mi	Attorney
Tom Tabler	W8WZH	Oh	Sales Engineer
Rex Kiser	-?????-	Mn	Unknown

A special thanks to all of you for subscribing. I have a large mailing going out to all of my previous customers and hope to be receiving the their subscriptions soon. The newsletter will be growing with each issue. It looks as though the number of radios coming in for repair has dropped and should give me the time I need to catch up on previous repairs that came in. Also, final transistors are now becoming more readily available with no problems in quality. This will enable me to give the Newsletter the full devotion it deserves. If anyone has anything they would like to contribute to the newsletter or has anything to sell, drop me a card. For members it is free of charge. I will also need additional people for the profile section. So send it in if you want to be included.